

SPECIFICATION

| | |
|-----------|-------------------|
| HS CODE | 8419.89. 9000 |
| PRODUCT | 500g SHOP ROASTER |
| MODEL No. | THCR-005 |

1. PRODUCT

500g shop roaster

2. PURPOSE

For training, sample roasting, single-origin roasting, in-shop production,

3. COMPONENTS

BODY + CYCLONE

4. TYPE

GAS (LPG / NATURAL GAS)

ELECTRIC

5. COLOUR

RED / MATT BLACK

6. FEATURES

MULTI PURPOSE ROASTER

EASY TO OBSERVE ROASTING PROCESS

QUICK BEAN RELEASE

CLEAN SILVER SKIN COLLECT

STABLE RADIANT HEAT TRANSFER AND HOT AIR

PRECISE AIR AND HEAT CONTROL

POWERFUL COOLING



7. SPEC

| | |
|-------------------------------------|---|
| DIMENSION (W) x (L) x (H) mm | 995 x 470 x 665 mm |
| POWER | 1 PHASE 220~240V 50~60Hz |
| WORK CAPACITY | MAX 500g / batch |
| WORKING TIME | 5~20 MINS |
| POWER CONSUMPTION | 0.1 kw (GAS TYPE) / 3.0kw (ELECTRIC) * DIRECT CONNECT |
| GAS PRESSURE | LOW PRESSURE FOR HOME USE |
| GAS CONSUMPTION | LPG 0.19kg/h LNG 2400kcal/h |

8. SIZE

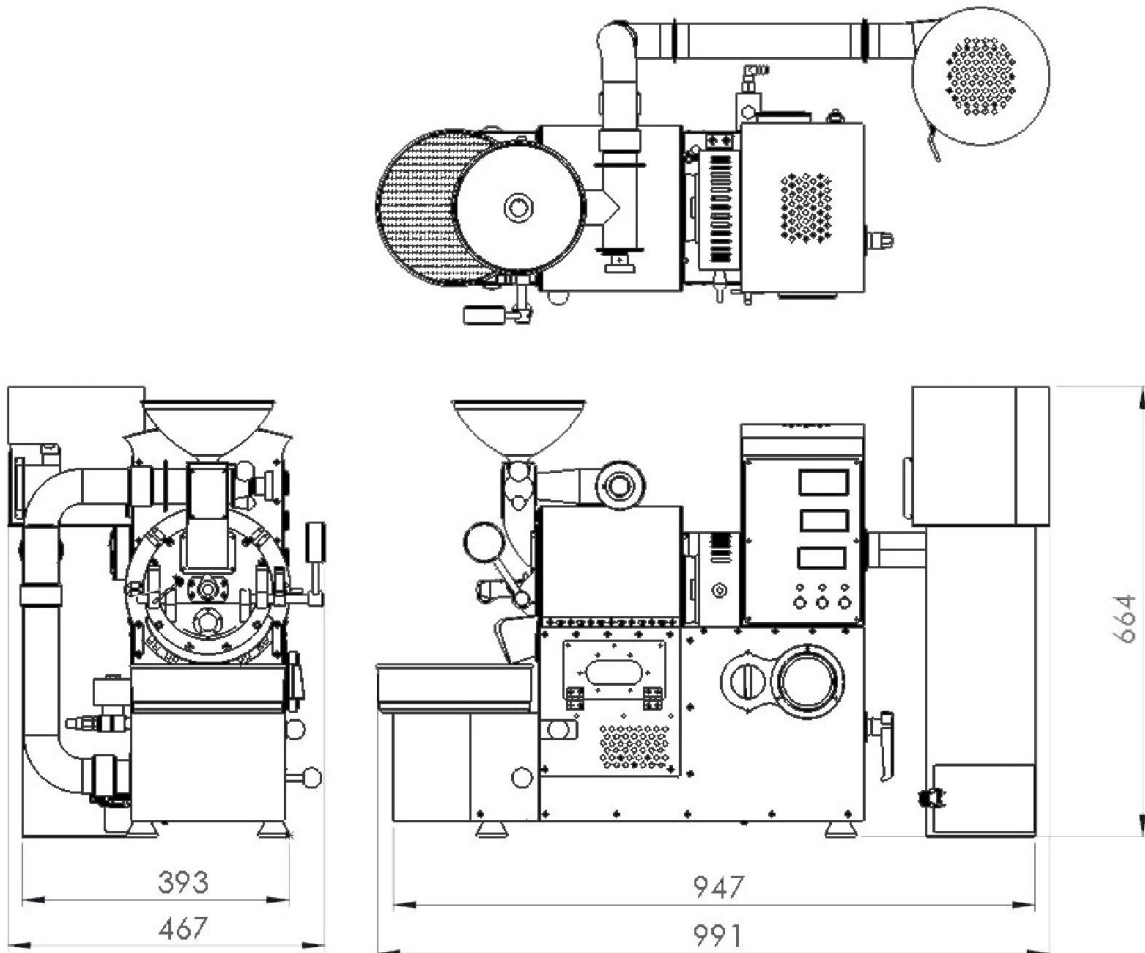

9. PREPARATION: TABLE, EXHAUST HOLE, GAS AND POWER SUPPLY

10. WARRANTY

ONE FULL YEAR FROM THE PURCHASE DATE

TWO YEARS PARTS WARRANTY IN CASE OF DIRECT PURCHASE FROM KOREA

WARRANTY IS NOT VALID IN CASE OF FOLLOWINGS.

- 1) SECOND-HAND MACHINE
- 2) NO SERIAL NO.
- 3) PROBLEMS FROM NOT FOLLOWING MANUAL GUIDELINE.
- 4) TROUBLES FROM WRONG GAS TYPE OR POWER, POOR PIPE LINE WORK, HUMIDITY, NO EARTH
- 5) NATURAL DISASTER / 6) POOR MAINTENANCE-CLEANING / 7) DIFFERENT USAGE / 8) INTENDED MISTAKE, MODIFICATION, SHOCK, DAMAGE, MAINTENANCE FROM NOT AUTHORIZED PERSON
- 9) NO OSERVATION DURING ROASTING.
- 10) USAGE OF NON GENUINE PARTS, CLEANING WITH WATER
- 10) FROM NOT FOLLOWING GENERAL SAFETY REGULATIONS
- 11) FROM EXTERNAL SURROUNDINGS
- 12) REWORK
- 13) CONSUMABLES

PROASTER
프로스터

T. (032) 624 3410~3

F. (032) 624 3414

E. taehwan.mj@gmail.com